

Magnum Combination Unit – MTT25 Specifications

ENGINE

- Isuzu® 4LE1NYGV-01 - liquid cooled, diesel engine
 - EPA Tier – Interim Tier IV
 - Standby – 35.3 hp @ 1800 rpm
 - Prime – 32.1 hp @ 1800 rpm
 - 4 cylinder
 - 2.20 L displacement
- Fuel consumption (prime) – 1.80 gph (6.81 Lph)
- 60 Hz engine/generator
- Industrial engine exhaust system
- Rubber vibration dampers isolate engine/generator from frame
- Cooling system capable of operating at 120°F ambient
- Full flow oil filter, spin on type
- Fuel filter with replaceable element
- Dry type cartridge air filter

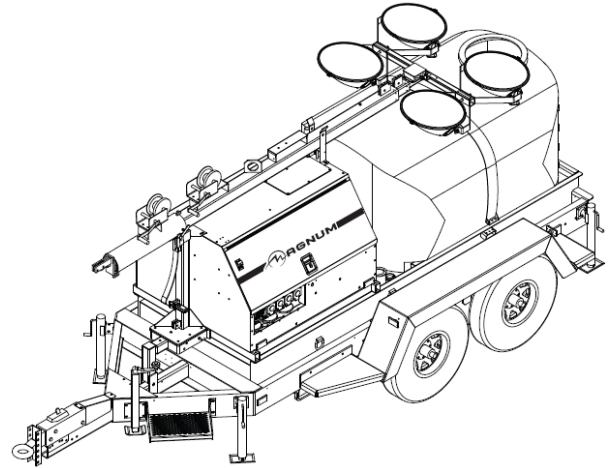

GENERATOR

- Marathon Electric®
 - Brushless
 - 4 pole
 - Class H insulation
- Voltage regulation +/- 1% with Marathon SE350 Voltage Regulator

SYSTEM OUTPUT

- 3 position selector switch
 - Single phase – 120 / 240V Zig Zag
 - Three phase – 120 / 208V Low Wye
 - Three phase – 277 / 480V High Wye
- 16 kW / 16 kVA – standby, single phase
- 15 kW / 15 kVA – prime, single phase
- 20 kW / 25 kVA – standby, three phase
- 18 kW / 23 kVA – prime, three phase

SYSTEM CONTROLS

- Microprocessor-based controller
 - Backlit, 128x64 pixel resolution display
 - -40°F to 185°F operating temperature range
 - Thermostatically controlled LCD heater

- Six LED indicators w/ lamp test
 - Alarm / Fault (Red)
 - Ready / Manual (Red)
 - Running (Green)
 - Warning (Yellow)
 - Ready / Auto (Green)
 - Supplying Load (Green)
- Push buttons for easy operation
 - Manual or Auto Start
 - Engine Start or Stop
 - Alarm Cancel & Fault Reset
 - Scrolling Arrows for Diagnostic Information
 - System kW output display
 - Line output & frequency display
 - Engine diagnostic display
 - Oil pressure
 - Engine temperature
 - Fuel level
 - Battery
 - System hours
 - Running hours
 - kW hours
 - Time to service
 - Alarm list – warnings / shutdowns are date & time stamped
 - Fuel level: warning – 15%; shutdown – 5%
 - Overspeed protection: shutdown – 115%
 - Oil pressure: warning – 25 psi; shutdown – 20 psi
 - Coolant temperature: warning – 220°F; shutdown – 230°F
 - Battery voltage: over – 15VDC; under – 11VDC
 - Generator over voltage: warning – 110%; shutdown – 111%
 - Generator under voltage: warning – 87%; shutdown – 86%
 - Generator over frequency: warning – 105%; shutdown – 110%
 - Generator under frequency: warning – 95%; shutdown – 90%
 - Over current shutdown

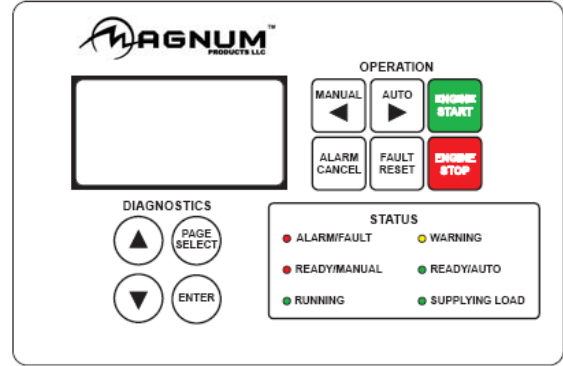

ELECTRICAL SYSTEM AND CONTROLS

- Individual floodlight circuits with 15A breakers
- Ballast indicator lights
- 90A start limit breaker (assures no load condition exists before starting)
- Standard individually breakered convenience outlets:
 - (2) 120 VAC 20 Amp GFCI duplex outlets (Nema 5-20R type)
 - (2) 240 VAC 30 Amp twistlock outlets (Nema L6-30R type)
 - (2) 240 VAC 50 Amp twistlock outlets (Non Nema 6369)
- 720 CCA wet cell battery

FLOODLIGHTS

- Four light fixtures – 1000 watts each - metal halide, quick disconnect
- Oval aluminum reflector
- Tempered glass lens



- Silicone gaskets for moisture and dust protection
- Individual floodlight On/Off switches

WIRING

- All wiring is sized to the amperage draw required
- AC & DC wiring diagrams are provided

LIGHT TOWER ENCLOSURE

- Steel enclosure – 14-gauge
 - UV& fade resistant, high temperature cured, white polyester powder paint
 - 68 dB(A) at 23 feet – prime power
- Stainless steel hinges on doors
- Multi-lingual operating/safety decals
- License plate holder with light
- Manual holder with operating manual

MAST

- 30' maximum extension, 3-section, tubular steel
- Self-lubricating, graphite guides on all sides of mast tubes
- Industrial black powder coat finish
- Automatic locking system in horizontal position for travel
- 1500 lb. automatic self-braking winches
- 360° rotation with locking system
- Coiled mast cord
- Dual winch system located at ergonomic height allowing single person operation
- Equipped with single lifting eye and fork pockets

WATER TANK & PUMP

- 500 gallon capacity
- ShurFLO® pump
 - 3.3 gpm (12.5 Lpm) - flow rate
 - 3.0 gpm (11.4 Lpm) - flow rate at hose bibb
- Hose bibb connections include (2) gravity and (2) pump

TRAILER

- Steel, single wall fuel tank
 - 246 gal. capacity
 - 127 hr. run time – full load
 - Fuel tank built into skid of generator set
- DOT approved tail, side, brake, and directional lights
 - Recessed rear lights
- Transportation tie downs
- Safety chains with spring loaded safety hooks
- 3" lunette ring hitch
- (2) 6000 lb. axles with surge brakes
- 5000 lb. tongue jack with footplate
- 7.50x16E-6-W tubeless tires – 10 ply



WEIGHTS & DIMENSIONS

- Dry weight: 5160 lbs (2341 kg)
- Operating weight: 10900 lbs (4944 kg)
- Mast stowed: 210 x 86 x 83 in (5.30 x 2.18 x 2.10 m)

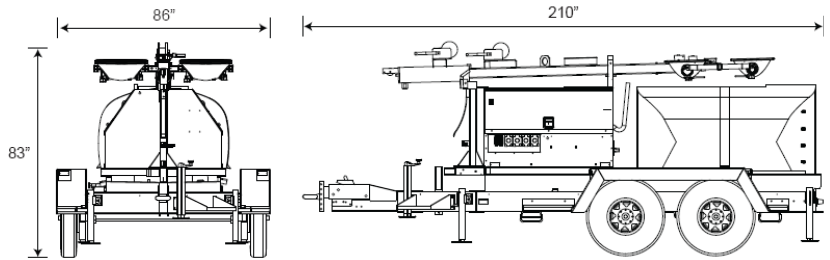

WARRANTY

- Engine and generator covered under OEM warranty – consult factory for details.

CERTIFICATIONS

- CSA certified

MTT25 Options

COOLANT OPTIONS

- ◆ 60/40 Coolant, 60% Ethylene glycol

ENGINE OPTIONS

- ◆ Heated fuel filter
- ◆ Lower radiator hose – engine heater

ELECTRICAL CONTROLS OPTIONS

- ◆ 720 CCA gel cell battery
- ◆ 685 CCA gel cell battery
- ◆ Battery disconnect
- ◆ Battery charger – 2A trickle
- ◆ Autolight controller
- ◆ Alternative receptacle panel – consult factory for configurations

CABINET OPTIONS

- ◆ Interior cabinet light
- ◆ Level indicator
- ◆ Containment/quiet pack
- ◆ Tamper pack

WATER TANK OPTIONS

- ◆ White water tank
- ◆ 120V pump heater

HITCH OPTIONS

- ◆ 2" ball
- ◆ 2 5/16" ball



TRAILER OPTIONS

- ◆ Spare tire and carrier
- ◆ Electric brakes

LIGHT OPTIONS

- ◆ High pressure sodium, quick disconnect lights

MAST CORD OPTIONS

- ◆ Drape cord

MAST, WINCH, & FINISH OPTIONS

- ◆ Galvanized, manual, dual winch
- ◆ Galvanized, electric, dual winch
- ◆ Galvanized, electric, dual winch, quick disconnect
- ◆ Black, electric, dual winch
- ◆ Black, electric, dual winch, quick disconnect

