

## Magnum Light Tower – MLT5060 Specifications

### ENGINE

- Mitsubishi® L3E-W461ML - liquid cooled, diesel engine
  - Standby - 12.2 hp @ 1800 rpm
  - Prime - 10.5 hp @ 1800 rpm
  - 3 cylinder
  - 0.95 L displacement
- Fuel consumption (prime) – 0.47 gph (1.78 Lph)
- 60 Hz engine/generator
- Industrial engine exhaust system
- Rubber vibration dampers isolate engine/generator from frame
- Cooling system capable of operating at 120°F ambient
- Full flow oil filter, spin on type
- Fuel filter with replaceable element
- Dry type cartridge air filter
- Polyethylene fuel tank with large diameter opening
  - 56 gal. capacity
  - 119 hr. run capacity
  - 3 ½" fill port

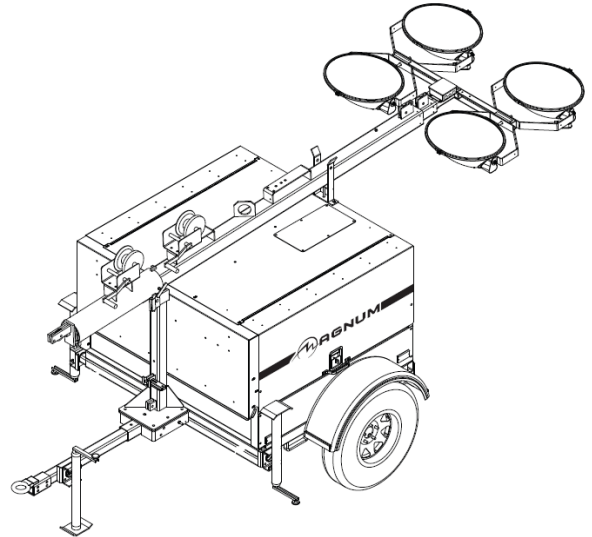

### ENGINE CONTROLS

- Engraved, aluminum punched and anodized control panel
- Four position keyed switch – glow plugs (preheat, off, run, start)
- Hour meter
- Automatic low oil/high temperature shutdown system

### GENERATOR

- Marathon Electric®
  - Brushless
- 6 kW standby output
- 120/240 VAC – 50/25A
- +/-6% capacitor voltage regulation

### ELECTRICAL SYSTEM AND CONTROLS

- Individual floodlight circuits with 15A breakers
- Ballast indicator lights
- Four cylindrical ballasts
- Individually canned transformers for proper heat dissipation
- 30A start limit breaker (assures no load condition exists before starting)

- Standard individually breakered convenience outlets:
  - (1) 120 VAC 20 Amp GFCI duplex outlets (Nema 5-20R type)
  - (1) 240 VAC 30 Amp twistlock outlets (Nema L6-30R type)
- 440 CCA wet cell battery

## FLOODLIGHTS

- Four light fixtures – 1000 watts each - metal halide, quick disconnect
- Oval aluminum reflector
- Tempered glass lens
- Silicone gaskets for moisture and dust protection
- Individual floodlight On/Off switches
- Internal cabinet light storage

## WIRING

- All wiring is sized to the amperage draw required
- AC & DC wiring diagrams are provided

## MAST

- 30' maximum extension, 3-section, tubular steel
- Urethane guides on all sides of mast tubes
- Industrial black powder coat finish
- Automatic locking system in horizontal position for travel
- 1500 lb. automatic self-braking winches
- 360° rotation with locking system
- Coiled mast cord
- Dual winch system located at ergonomic height allowing single person operation
- Equipped with single lifting eye and fork pockets

## ENCLOSURE

- Steel enclosure – 14-gauge
  - UV& fade resistant, high temperature cured, white polyester powder paint
  - 68 dB(A) at 23 feet – prime power
- Stainless steel hinges on doors
- Multi-lingual operating/safety decals
- License plate holder with light
- Manual holder with operating manual

## TRAILER

- Mast support - 3" square tube, 1/4" wall
- Removable tongue - 48" long
- Tubular steel frame - 3/16" wall
- Four, 2000 lb. adjustable leveling jacks – 4 point stance
- All jacks transport and lock in horizontal position for storage
- Side outriggers - 12' 7" span
- Safety chains with spring loaded safety hooks
- Combo hitch – 2" ball hitch and 2 1/2" pintle ring
- Single wall polyethylene fenders



- DOT approved tail, side, brake, and directional lights
  - Recessed rear lights
- 3500 lb. leaf spring axle
- ST205/75R15 – 6 ply
- 68.5 in. axle span

## WEIGHTS & DIMENSIONS

- Dry weight: 1771 lbs (803 kg)
- Operating weight: 1920 lbs (871 kg)
- Mast stowed: 170 x 78 x 72 in (4.32 x 1.98 x 1.83 m)

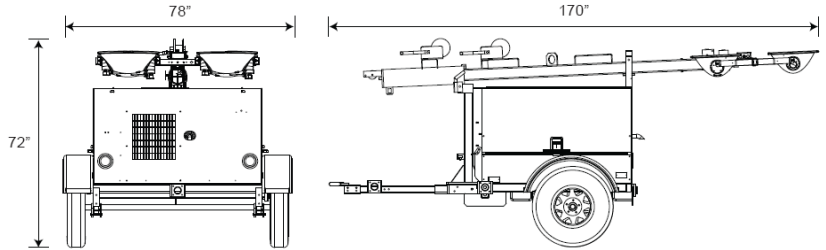

## WARRANTY

- Engine and generator covered under OEM warranty – consult factory for details.

## CERTIFICATIONS

- CSA certified

---

## MLT5060 Options

### COOLANT OPTIONS

- ◆ 60/40 Coolant, 60% Ethylene glycol

### ENGINE OPTIONS

- ◆ Heated fuel filter
- ◆ Oil drain valve kit
- ◆ Lower radiator hose – engine heater

### ELECTRICAL CONTROLS OPTIONS

- ◆ 720 CCA wet cell battery
- ◆ 720 CCA gel cell battery
- ◆ 775 sealed AGM battery
- ◆ Battery disconnect
- ◆ Battery charger – 2A trickle
- ◆ Autolight controller
- ◆ Alternative generator – electronically regulated

### CABINET OPTIONS

- ◆ Interior cabinet light
- ◆ Level indicator



## HITCH OPTIONS

- ◆ 2.5" lunette ring
- ◆ 3" lunette ring
- ◆ 3" HD lunette ring
- ◆ 2 5/16" ball
- ◆ 2" ball

## TRAILER OPTIONS

- ◆ Tube and sleeve jack
- ◆ 6 pin or 7 spade connectors
- ◆ Spare tire and carrier
- ◆ Parking brake
- ◆ Electric brakes
- ◆ Surge brakes

## LIGHT OPTIONS

- ◆ Tubelight™ Diffused Light accessory
- ◆ High pressure sodium

## MAST CORD OPTIONS

- ◆ Drape cord

## MAST, WINCH, & FINISH OPTIONS

- ◆ Galvanized, manual, dual winch
- ◆ Galvanized, electric, dual winch
- ◆ Galvanized, electric, dual winch, quick disconnect
- ◆ Black, electric, dual winch
- ◆ Black, electric, dual winch, quick disconnect

